

A - A

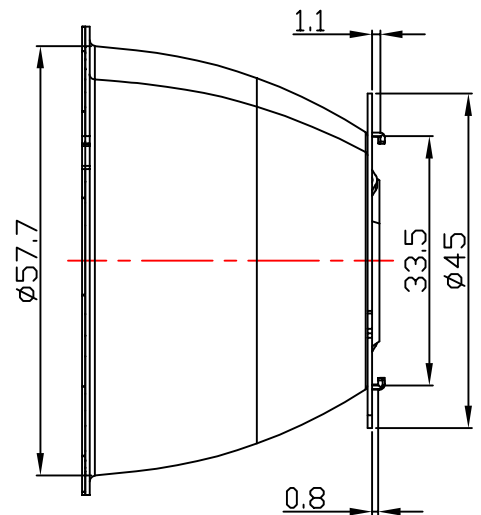

Light Source	LUMILEDS 1205
PlasticHolder	92.70.411.00
Metal Adaptor	
Design Angle	$50^\circ \pm 5^\circ$
Measured Angle	49.3°
Efficiency	

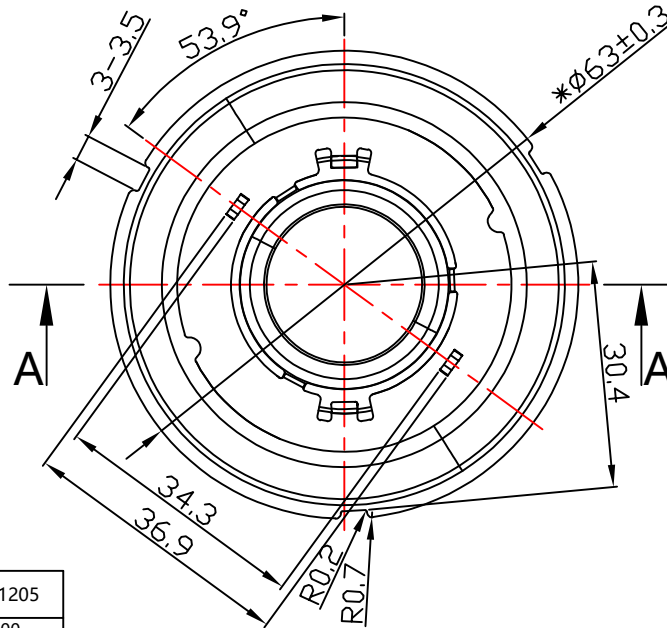
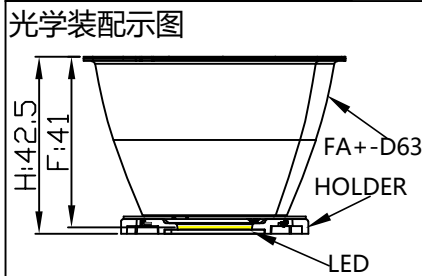

- Technical requirements:
- 1.**KEY CONTROL DIMENSION.
 - 2.Tolerances not noted are in accordance with the tolerance table.
 - 3.unmarked rounded corners Press for 3D.
 - 4.Surface without imprint, black spots, cracks, wrinkles and other poor.

PRODUCT BOM				
NO.	PRODUCT NAME	P/N:	QUANTITY	MATERIAL/FINISH
①	2-2641-L卡扣	97.77.073.00	1	T=0.6mm SUS301
②	2-2568-A	94.02.2568.000	1	T=0.6mm 1070AL/Andoizing
③	2-2569-A	94.02.2569.000	1	T=0.4mm High reflectivity aluminum(Mirror surface)

标记 MARK	处数 NO.OF MODIF	更改内容 MODIFICATIONS	签名 SIGNED BY	更改日期 MODIF. DATE
设计 DESIGNER	制图 DRAWN BY	审核 CHECKED BY	比例 SCALE	1:1
工艺 TECHNICAN	日期 DATE(DD-MM-YYYY)	17-10-2022	视角 1st ANGLE PROJECTION	
批准 APPROVED BY	日期 DATE(DD-MM-YYYY)	17-10-2022	页数 PAGE	SHEET 1 OF 1

DIMENSION TOLERANCE TABLE (UNLESS OTHERWISE STATED)						
> 0-5	> 5-30	> 30-90	> 90-150	> 150-250	> 250-400	> 400-700
±0.15	±0.2	±0.4	±0.5	±0.8	±1.5	±2
PUNCH TOLERANCE TABLE (UNLESS OTHERWISE STATED) (ANGLE)						
> 0-10	> 10-50	> 50-120	> 120-250	> 250-360		
±1°	±0.5°	±0.3°	±0.2°	±0.166°		

		版本 VERSIONS	K
		产品编码 PRODUCT CODE	91.02.2642.000
产品名称 PRODUCT NAME		2-2642-L	
客户代号 CUSTOMER ID		NT	
客户编号 CUSTOMER CODE		FA+-63-50D	

产品图
PRODUCT DRAWING

单位
UNIT
mm